



**coerco**

# **AGRICULTURE**

---

Product Catalogue  
April 2026

---



# Contents

---

## Company Profile 4-6

About Us	4
Company History	4
Coerco Means	5
Knowledgeable and Flexible Logistics	6

## Water Tanks 7-16

Premium Corrugated Water Tanks	8-9
Premium Flat Walled Water Tanks	10-11
Slimline Water Tanks	12
Tank Fittings & Accessories	13-15
Standard Colour Options	16

## Animal Products 17-21

All Poly Stock Troughs	18
M Series Water Troughs	19
M Series Feed Troughs	19
Ultra Tub Troughs	20-21
Cup and Saucer Tanks	22

## Liquid Fertiliser Products 23-28

Liquid Fertiliser Storage Tanks	24
Liquid Fertiliser Free-Standing Transport Tanks	25
Liquid Fertiliser Free-Standing Transport Tank Skid Frames	25
Liquid Fertiliser Sump-Based Transport Tanks	26
Liquid Fertiliser Sump-Based Transport Tank Skid Frames	27
Bulk Liquid Fertiliser Units	28

## Transport Tanks 29-34

Free-Standing Transport Tanks	30
Free-Standing Transport Tank Skid Frames	31
Sump-Based Transport Tanks	32
Sump-Based Transport Tank Skid Frames	33
Ball Baffle System	34
Transport Tank Lids and Strainer Basket	34

# Contents

<b>Fire Fighting Equipment</b>	<b>35-40</b>
Skid Mount Fire Fighting Units	36
Compact Fire Fighting Units	37
Wellbody Fire Fighting Units	38
Trailed Fire Fighting Units	39
Hose Reels	40
<b>Diesel Products</b>	<b>41-48</b>
Diesel Storage Tanks	42
Trailed Diesel Transport Equipment	43-44
Diesel Free-Standing Transport Tanks	45
Diesel Free-Standing Transport Tank Skid Frames	46
Diesel Transport Units	47
Diesel Transfer Accessories	48
<b>Wastewater Systems</b>	<b>49-50</b>
Septic Tanks	50
<b>Effluent Disposal Systems</b>	<b>51</b>
HydraDrain Modular Leach Drains	51
<b>General Conditions</b>	<b>52</b>
<b>Delivery Information</b>	<b>53-54</b>
<b>Tank Order Form</b>	<b>55-56</b>

## DISCLAIMER

Be advised that some information found in our catalogue may contain typographical errors, inaccuracies, or omissions on product descriptions, specifications, pricing, and other details.

Information on weight, measurement, and colours, are the best approximates possible.

Coerco cannot guarantee and assumes no legal liability or responsibility for the accuracy or completeness of the information provided. Coerco reserves the right to change, delete, or otherwise modify the information represented without any prior notice.

## Company Profile



### ABOUT US

Coerco is an established and trusted Australian manufacturer and supplier of innovative polyethylene products essential for every type of liquid, storage and transportation. Delivering world-class products is the highest priority along with striving to improve lives by innovating in the agricultural industry and creating opportunities within the market.

With the best support network of key distributors, Coerco understands the specific issues faced by the farming community. Coerco's key distributors are in every major township across Western Australia.

As a leading liquid storage manufacturer and supplier in Australia with decades of experience and expertise to provide quality in every aspect of its products, Coerco has an outstanding range of equipment. Every aspect of the manufacturing process is closely monitored to the highest quality from water, liquid fertiliser and diesel storage to fire fighting equipment and sewerage treatment.

### COMPANY HISTORY AND RURAL ROOTS

Coerco has been supplying Western Australia with a range of innovative polyethylene liquid storage solutions designed to meet the needs of agriculture for more than 30 years. The company was created by Coerco's Founder, Andrew Jackson in 1993 as Rapid Plastics and added a subsidiary in the industrial sector called Multi-Tech. In 2016 the company underwent a major rebranding and merged the two companies to form Coerco.

As a proudly Australian Owned Certified business (#08515), Coerco has always committed to supporting the rural community from its factory in Dalwallinu, which employs more than 150 staff and donates to multiple rural causes and charitable groups. By growing its company in a small country town, Coerco understands the issues facing rural WA.



## Company Profile



### COERCO MEANS

Coerco is renowned for providing quality products to the agricultural market in WA. Products that are easy to use, simple to install and long lasting. Coerco's simple ordering and delivery service, reliable warranties and after-sales service are second to none.

#### Rural Knowledge

Coerco's experienced sales team understands each local area and is equipped with rural knowledge to assist with livestock products, liquid management, fire fighting or septic system requirements.

#### Australian Made

Coerco's team has more than 150 years of combined industry experience with an expansive factory in Dalwallinu, modern offices in Malaga and fabrication centres in Bunbury and Northam, with products made to suit the harsh and changing Australian climate.

Continuous innovation ensures every poly product is designed for peak performance to meet the needs of farmers across Western Australia.

#### Customer Care

Dedicated and experienced staff monitor every aspect of each product order to ensure a seamless and trouble-free experience. Complete customer satisfaction is at the centre of Coerco's business philosophy with the Coerco team maintaining regular and open communication throughout the purchasing process and for after-sales feedback.

# Company Profile

---



## KNOWLEDGEABLE AND FLEXIBLE LOGISTICS

### Distribution Network

A reliable supply of Coerco products available across the state

Coerco's large range of liquid storage solutions, agricultural products, septic systems and fire fighting units are readily accessible in convenient locations throughout rural regions of WA. The knowledgeable local staff provide expert guidance on the best type, size and colours to choose from as well as tips and advice on installation and maintenance. Coerco has held a strong relationship with its rural dealer network since the 1990s, which also helps to support local communities and businesses.

### Logistics

A comprehensive logistics team keeps its fleet of trucks moving

Coerco has a large, specialised transport fleet with decades of experience and connections to proven transport networks. The fleet is part of an agile operation to coordinate deliveries to remote locations, when it suits our customers. Our transport and logistics team is experienced in the planning and delivery of products to remote locations. More than 10 permanent truck drivers are complemented by on call staff to provide a 24-hour, five-day-a-week transport service.

### Warranty and After-Sales Care

At Coerco, complete customer satisfaction is a critical driving force of the business philosophy, and this extends to warranty. Each product includes guaranteed manufacturer support for the period stated after purchase. This means the product is warranted against defects or faults caused by poor workmanship or inferior quality.



# Water Tanks

**The Thickest, Time-Tested Poly Water Tanks To Ever Exist In Rural Western Australia.**

Manufactured & Designed by Rural Aussies for Rural Aussies, reliable Coerco water tanks help put seasonal goals within your reach, just what every Australian agriculture business needs.

## KEY FEATURES

- One-piece construction
- Durable and impact-resistant polyethylene for long life
- Engineered and certified to meet Australian Standards (AS 4766:2020)
- Available in an array of colours

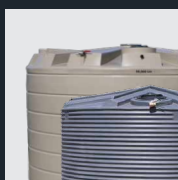

All Include Self-Supporting Roof



UV-Stabilised



Made of Polyethylene

## Premium Corrugated Water Tanks



### FEATURES

- One-piece construction
- Attractive heritage design
- Corrugated for strength and traditional appearance
- UV-stabilised to withstand our harsh climate
- Durable and impact-resistant polyethylene for long life
- Engineered and certified to meet Australian Standards (AS 4766:2020)
- Self-supporting lid design eliminates need for centre support pole
- Available in a range of colours (See page 16)

### Premium Corrugated Water Tanks

Code	Litre	Gallons	Diameter (mm)	Inlet Height (mm)	Total Height (mm)	List Price (incl. GST)
RT1000	1,000	220	1000	1485	1495	\$804.10
RT2500	2,500	550	1350	1860	2030	\$1,203.40
RT2500S	2,500	550	1850	1051	1250	\$1,203.40
RT4500	4,500	1,000	1850	1950	2100	\$1,551.00
RT4500S	4,500	1,000	2420	1200	1350	\$1,697.30
RT9000	9,000	2,000	2420	2255	2440	\$2,678.50
RT9000S	9,000	2,000	2950	1560	1825	\$2,856.70
RT9500	9,500	2,100	2600	1951	2150	\$2,928.20
RT13500	13,500	3,000	2950	2075	2325	\$3,393.50
RT22500	22,500	5,000	3550	2550	2824	\$4,748.70
RT32000	32,000	7,050	3950	2740	3025	\$6,694.60

### 2 Tanks Special Offer

Code	Description	List Price (incl. GST)
RT22500	2 × 22,500 Ltr Water Tank (45,000 Ltr)	\$4,654.10 (per tank)
RT32000	2 × 32,000 Ltr Water Tank (64,000 Ltr)	\$6,563.70 (per tank)

# Premium Corrugated Water Tanks



## Standard Fittings



90mm PVC Mesh Overflow



Strainer Basket



Screw on Lid



Ball Valve



40mm Brass Outlet (for tap)

## Optional Extra



40mm Brass Inlet

Please note that fittings can be customised to your requirement.



## Premium Flat Walled Water Tanks



### FEATURES

- One-piece construction
- Sturdy, reliable and built to last
- UV-stabilised to withstand our harsh climate
- Supplied with screw in lid, overflow, outlet and ball valve
- Engineered and certified to meet Australian Standards (AS 4766:2020)
- Self-supporting lid eliminates need for centre support pole
- Available in all of our colour range (See page 16)

### Premium Flat Walled Water Tanks

Code	Litres	Gallons	Diameter (mm)	Inlet Height (mm)	Total Height (mm)	List Price (incl. GST)
JRR5300	5,300	1,200	1800	2305	2325	\$1,872.20
JRR10500	10,500	2,400	2540	2450	2500	\$3,598.10
JRR14000	14,000	3,100	2540	3180	3200	\$3,702.60
JRR25000	25,000	5,500	3825	2560	2640	\$5,039.10
JRR50000	50,000	11,100	4575	3315	3400	\$12,182.50

### 2 Tanks Special Offer

Code	Description	List Price (incl. GST)
JRR25000	2 × 25,000 Ltr Water Tank (50,000 Ltr)	\$4,939.00 (per tank)
JRR50000	2 × 50,000 Ltr Water Tank (100,000 Ltr)	\$11,939.40 (per tank)

# Premium Flat Walled Water Tanks



## Standard Fittings



90mm PVC Mesh Overflow



Strainer Basket



Screw on Lid



Ball Valve



40mm Brass Outlet (for tap)

## Optional Extra



40mm Brass Inlet

Please note that fittings can be customised to your requirement.

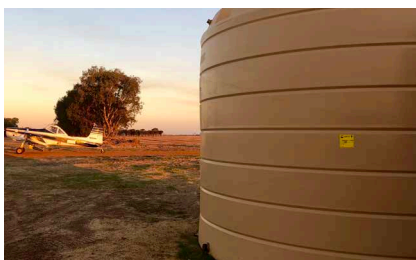



## Slimline Water Tanks



### FEATURES

- Attractive space-saving design
- Ideal for under the eaves or pathway placements
- Engineered and certified to meet Australian Standards (AS 4766:2020)
- Available in all of our colour range (See page 16)

### Slimline Water Tanks

Code	Description	Dimensions (mm)	Inlet Height (mm)	Total Height (mm)	List Price (incl. GST)
RTS800	800Ltr Slimline Tank	 625 1250	1450	1500	\$886.60
RTS1500	1,500Ltr Slimline Tank	 875 1325	1950	2000	\$1,167.10
RTS3000	3,000Ltr Slimline Tank	 805 2615	2070	2120	\$2,141.70

### Standard Fittings



90mm PVC Mesh Overflow



Strainer Basket



Screw on Lid



Bibcock Tap



25mm Brass Outlet (for tap)



25mm Drain Bung

## Tank Fittings & Accessories



### Lids & Overflows

Code	Description	List Price (incl. GST)
COMP-33-05-PPE	355mm Screw Lid	\$89.10
COMP-33-07-PPE	355mm Strainer Basket	\$70.40
COMP-33-08-PPE	455mm Screw Lid	\$122.10
COMP-33-09-PPE	455mm Strainer Basket	\$84.70
TAL-5	90mm PVC Mesh Overflow	\$19.80



### Ball Valves & Taps

Code	Description	List Price (incl. GST)
COMP-38-01	20x20mm Brass Bibcock Tap	\$27.50
COMP-37-01	Brass Lever Ball Valve - 25mm BSP Thread	\$38.50
COMP-37-02	Brass Lever Ball Valve - 32mm BSP Thread	\$58.30
COMP-37-03	Brass Lever Ball Valve - 40mm BSP Thread	\$74.80
COMP-37-04	Brass Lever Ball Valve - 50mm BSP Thread	\$133.10
COMP-37-07	Brass Lever Ball Valve - 80mm BSP Thread	\$245.30
COMP-37-08	Brass Lever Ball Valve - 100mm BSP Thread	\$358.60
COMP-36-01	Poly Ball Valve - 25mm BSP Thread	\$35.20
COMP-36-02	Poly Ball Valve - 32mm BSP Thread	\$50.60
COMP-36-03	Poly Ball Valve - 40mm BSP Thread	\$66.00
COMP-36-04	Poly Ball Valve - 50mm BSP Thread	\$89.10
COMP-36-05	Poly Ball Valve - 80mm BSP Thread	\$118.80
COMP-36-06	Poly Ball Valve - 100mm BSP Thread	\$217.80

# Tank Fittings & Accessories

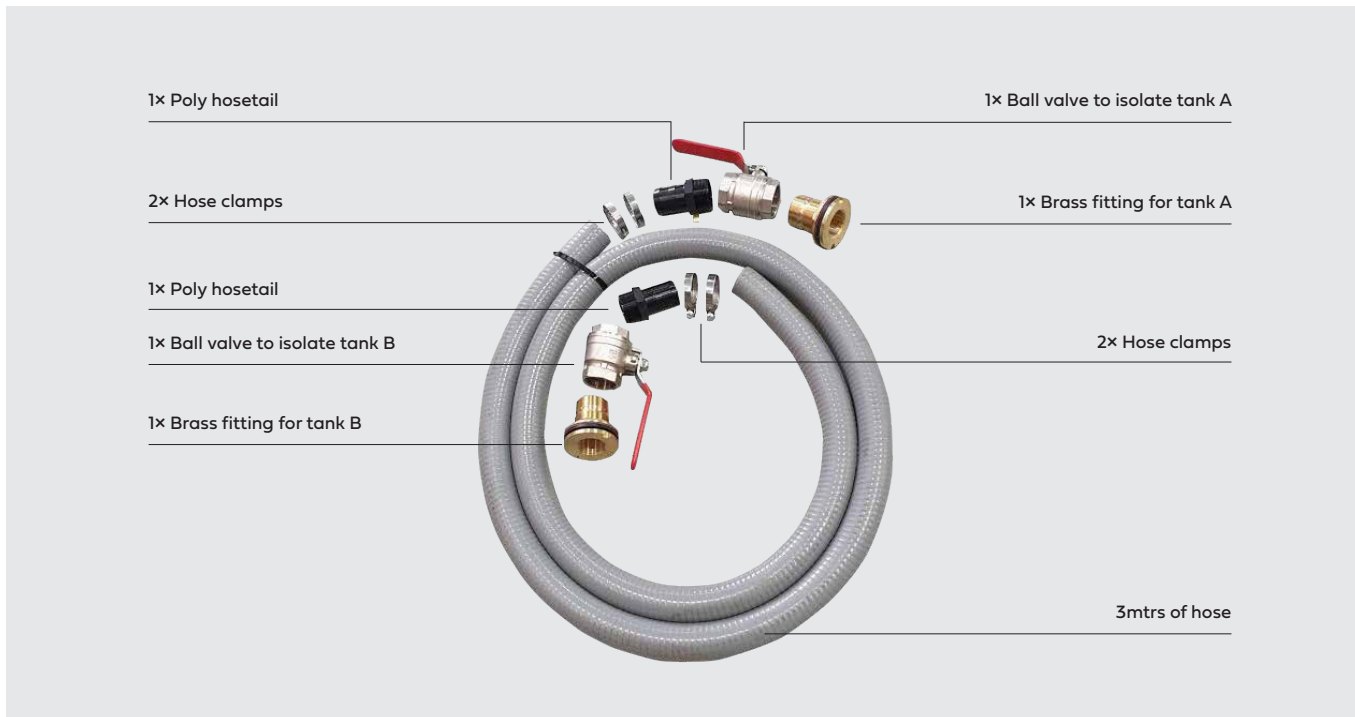

## FEATURES

- Connector Kit to join two poly tanks at the base
- Complete set ready for installation
- Extend your water storage capacity with combo tanks

## Combo Tank Joiner Kits

Code	Description	List Price (incl. GST)
TJK-01	Combo Tank Joiner Kit - includes 3mtrs 40mm hose & fittings to connect 2x Poly tanks at base	\$193.60

TJK-02	Combo Tank Joiner Kit - includes 3mtrs 50mm hose & fittings to connect 2x Poly tanks at base	\$266.20
--------	--	----------

# Tank Fittings & Accessories

## Tank Level Gauges

Code	Description	List Price (incl. GST)
TAL-7	Dip-stick tank level gauge	\$305.80
TAL-10	"Liquidator" tank level gauge	\$245.30



Dipstick (TAL-7)



Liquidator (TAL-10)



## Tank Flange Fittings

Code	Description	List Price (incl. GST)
COMP-01-01	25mm (1") Brass Fitting	\$45.10
COMP-01-02	32mm (1¼") Brass Fitting	\$48.40
COMP-01-03	40mm (1½") Brass Fitting	\$49.50
COMP-01-04	50mm (2") Brass Fitting	\$62.70
COMP-01-05	80mm (3") Brass Fitting	\$179.30
COMP-01-06	100mm (4") Brass Fitting	\$310.20
COMP-19-02	25mm (1") Poly Fitting	\$16.50
COMP-19-03	32mm (1¼") Poly Fitting	\$29.70
COMP-19-04	40mm (1½") Poly Fitting	\$36.30
COMP-19-05	50mm (2") Poly Fitting	\$38.50
COMP-19-06	80mm (3") Poly Fitting	\$125.40
COMP-19-07	100mm (4") Poly Fitting	\$167.20

## FEATURES

### Dipstick (TAL-7)

- Floating pole type water level gauge
- Out of reach of animals
- 360° all round visibility
- Great for Cup & Saucer Tanks

### Liquidator (TAL-10)

- Ideal for chemical tanks, only the float is in contact with liquid
- Protected guided indicator, isn't bothered by wind or other disturbances

## FEATURES

### Brass Tank Fittings

- Locking nut is left hand thread for secure fit. Doesn't come loose when fitting valves etc
- 25-50mm have internal and external threads
- 80-100mm have external thread

### Poly Tank Fittings

- Available in 6 sizes.
- Manufactured from UV-stabilised glass fibre reinforced nylon to protect from weather, termite, fungi and bacteria.

## Standard Colour Options

Coerco poly water tanks are designed and manufactured under strict control to ensure they are suitable for drinking quality and fully UV-stabilised in all colours to survive our harsh climate.

Our tanks are manufactured using the certified polyethylene resins or powder to meet the following standards (for 1.0 SG water tanks):

- AS/NZS 4766:2020 Polyethylene storage tanks for water and chemicals
- AS/NZS 4020 Australian Standard for drinking water
- AS 2070 Part 1 and Part 8 Australian Standard for food contact

### STANDARD STOCKED COLOURS



**Beige**  
11CBEI



**Smooth Cream**  
(Classic Cream®)  
11CSC



**Mist Green**  
(Pale Eucalypt®)  
11MCSG



**Heritage Green**  
(Cottage Green®)  
11HGN



**Slate Grey**  
(Woodland Grey®)  
11CBS

### OTHER COLOURS AVAILABLE



**Black**  
(Night Sky®)  
11BLK



**Charcoal**  
(Monument®)  
11CHA



**Merino**  
(Paperbark®)  
11CBM



**Gull Grey**  
(Shale Grey®)  
11GUL



**Off White**  
(Surfmist®)  
11TWT



**Heritage Red**  
(Manor Red®)  
11HRD



**Mountain Blue**  
(Deep Ocean®)  
11MTB



**Torriss Blue**  
11TBU



**Rivergum**  
(Wilderness®)  
11CRG



**Wheat**  
(Harvest®)  
11WHE

Optional COLORBOND® colours are available but may be subject to surcharge and/or delivery delay. Due to printing differences, some colours may vary. COLORBOND® and colour names are registered trademarks of Blue Scope Steel Ltd.™Colour names are trademarks of Blue Scope Steel Ltd. Coerco colours represented match COLORBOND® steel colours.



# Animal Products

## Built Tough for Everyday Farm Use.

Coerco has the largest range of polyethylene equipment for animal management in Western Australia. Whether your priority is efficiency, value-for-money, durability, ease of use or all of the above, our products and excellent customer service tick all the right boxes!

### KEY FEATURES

- Made of durable poly for lasting performance
- Manufactured in guidance of Australian Standards
- UV-stabilised for harsh climate conditions
- One-piece construction



Standard Colour  
is Beige

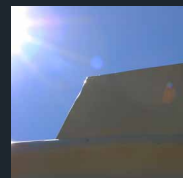

UV-Stabilised



Covered Float

## All Poly Stock Troughs

### FEATURES

- Standard with 25mm (1") float valve
- Optional with 32mm (1¼"), 40mm (1½") or 50mm (2") float valve
- Unmatched strength through one-piece moulding
- Exceptionally durable and versatile
- Easy to clean with round sweep out end
- Standard colour is beige
- Full float valve protection  
Designed and manufactured in WA for harsh local conditions
- Optional waterfilled base for improved stability
- Peg down points to prevent livestock pushing trough around



### All Poly Stock Troughs

Code	Description	Length (mm)	Width (mm)	Height (mm)	List Price (incl. GST)
PTR39X	130Ltr All Poly Stock Trough - without float valve	2400	450	420	\$761.20
PTR39W	130Ltr All Poly Stock Trough - with 25mm float valve	2400	450	420	\$817.30
PTR40X	200Ltr All Poly Stock Trough - without float valve	3600	450	420	\$1,026.30
PTR40W	200Ltr All Poly Stock Trough - with 25mm float valve	3600	450	420	\$1,081.30
PTR60X	308Ltr All Poly Stock Trough - without float valve	3600	580	460	\$1,138.50
PTR60W	308Ltr All Poly Stock Trough - with 25mm float valve	3600	580	460	\$1,194.60

### Float Valve Upgrades

Code	Description	List Price (incl. GST)
+32LP	Float Valve upgrade to 32mm (1¼") Low Pressure	\$106.70
+32HP	Float Valve upgrade to 32mm (1¼") High Pressure	\$106.70
+40LP	Float Valve upgrade to 40mm (1½") Low Pressure	\$149.60
+40HP	Float Valve upgrade to 40mm (1½") High Pressure	\$149.60
+50LP	Float Valve upgrade to 50mm (2") Low Pressure	\$183.70
+50HP	Float Valve upgrade to 50mm (2") High Pressure	\$183.70

# M Series Troughs



## M Series Water Troughs

Code	Description	Length (mm)	Width (mm)	Height (mm)	List Price (incl. GST)
PTM33W	110Ltr Water Trough - with 15mm float valve	1200	580	250	\$403.70
PTM31W	230Ltr Water Trough - with 15mm float valve	2400	580	250	\$553.30



## M Series Feed Troughs

Code	Description	Length (mm)	Width (mm)	Height (mm)	List Price (incl. GST)
PTM33F	110Ltr Feed Trough - no float valve	1200	580	250	\$246.40
PTM31F	230Ltr Feed Trough - no float valve	2400	580	250	\$401.50

### FEATURES

- Water troughs only available with 15mm float valve
- Strong all-poly construction suitable for corrosive environments
- Light and easy to handle facilitates relocation
- Smooth finish for ease of cleaning
- Peg down points to prevent livestock pushing trough around
- Covered float on water troughs prevents stock damage to float

## Ultra Tub Troughs



### FEATURES

- Float compartment moulded as part of the trough
- Raised float to allow complete filling of trough
- All pipework protected by trough surround
- 50mm drain bung
- Exceptionally strong design
- Stainless steel float valve cover fasteners

### Ultra Tub Troughs

Code	Description	Diameter (mm)	Height (mm)	List Price (incl. GST)
PTU3	250Ltr Ultra Tub Trough - with 15mm float valve	1100	450	\$575.30
PTU6	600Ltr Ultra Tub Trough - with 25mm float valve	1400	550	\$948.20
PTU12	1200Ltr Ultra Tub Trough - with 25mm float valve	1750	600	\$1,194.60
PTU25	2500Ltr Ultra Tub Trough - with 25mm float valve	2400	650	\$1,872.20

# Ultra Tub Troughs

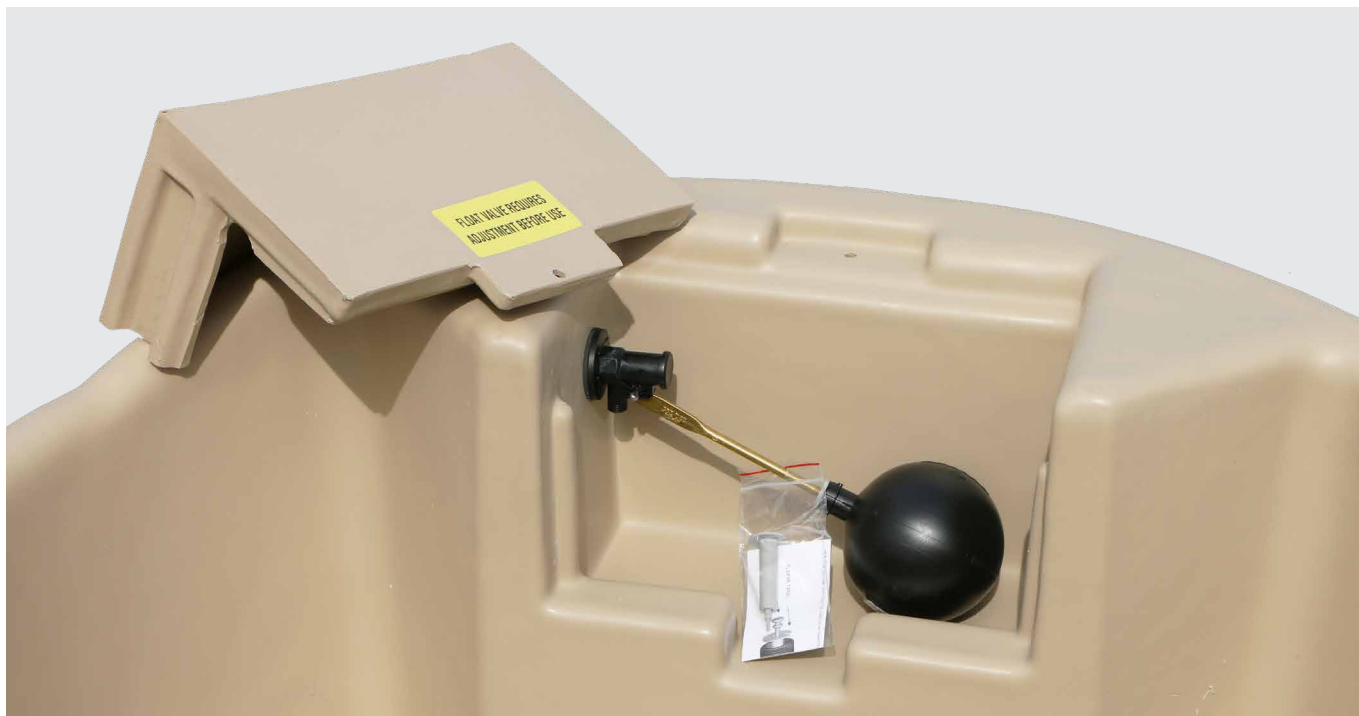

Float valve protected by slide up access cover

## Float Valve Upgrades

Code	Description	List Price (incl. GST)
+32LP	Float Valve upgrade to 32mm (1¼") Low Pressure	\$106.70
+32HP	Float Valve upgrade to 32mm (1¼") High Pressure	\$106.70
+40LP	Float Valve upgrade to 40mm (1½") Low Pressure	\$149.60
+40HP	Float Valve upgrade to 40mm (1½") High Pressure	\$149.60
+50LP	Float Valve upgrade to 50mm (2") Low Pressure	\$183.70
+50HP	Float Valve upgrade to 50mm (2") High Pressure	\$183.70

\*PTU3 is not available with float valve upgrades

## Cup and Saucer Tanks



### FEATURES

- 25mm (1") inlet and saucer float valves
- Extremely durable
- Tie-down lugs on tank
- Easy action float cover with all stainless steel fasteners - no rust
- High/Low level inlets for filling at ground level or straight from windmill etc
- 50mm drain plug in all size saucers
- Standard in beige colour with float cover and stainless steel fasteners. Other colours available with a 10% surcharge and additional delivery time

### Cup and Saucer Tanks

Code	Description	Diameter (mm)	Height (mm)	List Price (incl. GST)
CS2700	600 Gallon / 2700Ltr Poly Cup & Saucer Tank	2000	2000	\$2,895.20
CS3000	660 Gallon / 3000Ltr Poly Cup & Saucer Tank	2400	1240	\$2,961.20
CS5000	1100 Gallon / 5000Ltr Poly Cup & Saucer Tank	2400	2000	\$3,730.10
CS10000	2200 Gallon / 10000Ltr Poly Cup & Saucer Tank	3300	2000	\$5,035.80



Protected float valve compartment and stainless steel fasteners.



# Liquid Fertiliser Products

## High-Quality Fertiliser Storage & Transport Tanks You Can Trust.

Coerco has revolutionised liquid fertiliser storage and transport with innovative polyethylene products—delivering greater value, efficiency, and profitability for Australian farmers.

### KEY FEATURES

- Certified design and analysis on structure
- Made of the highest quality poly, Coerco's liquid storage tanks are UV-stabilised to withstand the harsh Australian landscape
- Comes with the necessary fittings and accessories needed for immediate use

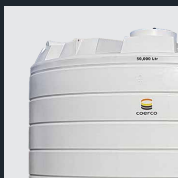

Standard Colour is White



UV-Stabilised



Fertiliser-safe, corrosion-resistant poly.

## Liquid Fertiliser Storage Tanks



### FEATURES

- Certified design and analysis on structure
- Durable, impact-resistant, UV-stabilised, chemical resistant poly material
- 80mm (3") suction port with butterfly valve, camlock and dust cap (includes elbow to draw from lowest point)
- 80mm (3") fill line including 25mm (1") drain for operator safety
- Tank level gauge for easy viewing of content volume
- Vented access hatch
- Approved for storage by all major liquid fertiliser companies

### Liquid Fertiliser Storage Tanks

Code	Description	Diameter (mm)	Height (mm)	List Price (incl. GST)
LF10500	10,500Ltr (14 Tonne) Liquid Fertiliser Storage Tank	2450	2450	\$6,483.40
LF25000	25,000Ltr (33 Tonne) Liquid Fertiliser Storage Tank	3825	2555	\$8,399.60
LF50000	50,000Ltr (65 Tonne) Liquid Fertiliser Storage Tank	4575	3400	\$16,186.50

### Liquid Fertiliser Storage Tank Accessories

Code	Description	List Price (incl. GST)
LF-2R	80mm (3") to 50mm (2") Reducer Fittings	\$80.30

## Liquid Fertiliser Free-Standing Transport Tanks



### FEATURES

- Special 'FNS' series range manufactured for transport of liquid fertilisers and chemicals with heavier SG ratings
- Easy to read calibrations<sup>†</sup>
- Strength through ingenuity of design
- Durable, impact-resistant, UV-stabilised polyethylene
- Stainless steel lid
- Sight tube for easy viewing of content volume<sup>†</sup>
- One outlet supplied with tank, quantity and sizes optional
- Integral foam filled baffle to reduce surge and increase stability<sup>\*\*</sup>
- Mounting pins supplied as standard, extra mounting pins available
- Optional Ball Baffle System available
- All free standing tanks available with forkliftable skid
- Poly fittings for easy connection
- Standard colour is white

### Liquid Fertiliser Free-Standing Transport Tanks

Code	Description	Length (mm)	Width (mm)	Height (mm)	List Price (incl. GST)
FNS2000FS	2,000Ltr Liquid Fert Free-Standing Transport Tank	1830	1400	1130	\$3,230.70
FNS3000FS	3,000Ltr Liquid Fert Free-Standing Transport Tank - Non Baffled	2365	1460	1300	\$4,601.30
FNS5000FS	5,000Ltr Liquid Fert Free-Standing Transport Tank - Non Baffled	2425	1830	1708	\$6,531.80
FNS7000FS	7,000Ltr Liquid Fert Free-Standing Transport Tank	3430	1850	1670	\$8,878.10
FNS10000FS	10,000Ltr Liquid Fert Free-Standing Transport Tank	3600	2100	1890	\$12,378.30
FNS12500FS	12,500Ltr Liquid Fert Free-Standing Transport Tank - Non Baffled	4000	2200	2250	\$15,545.20
FNS17000FS	17,000Ltr Liquid Fert Free-Standing Transport Tank - Non Baffled	4450	2300	2350	\$21,880.10

### Liquid Fertiliser Free-Standing Transport Tank Skid Frames

Code	Description	List Price (incl. GST)
SKD-FS-2000HDG	Hot Dip Galvanised Skid Frame To Suit 2,000L Free-Standing Transport Tank - Fork Accessible	\$3,426.50
SKD-FS-3000HDG	Hot Dip Galvanised Skid Frame To Suit 3,000L Free-Standing Transport Tank - Fork Accessible	\$4,669.50
SKD-FS-5000HDG	Hot Dip Galvanised Skid Frame To Suit 5,000L Free-Standing Transport Tank - Fork Accessible	\$5,467.00
SKD-FS-7000HDG	Hot Dip Galvanised Skid Frame To Suit 7,000L Free-Standing Transport Tank - Fork Accessible	\$7,360.10
SKD-FS-10000HDG	Hot Dip Galvanised Skid Frame To Suit 10,000L Free-Standing Transport Tank - Fork Accessible	\$7,529.50
SKD-FS-12500HDG	Hot Dip Galvanised Skid Frame To Suit 12,500L Free-Standing Transport Tank - Fork Accessible	\$9,432.50
SKD-FS-17000HDG	Hot Dip Galvanised Skid Frame To Suit 17,000L Free-Standing Transport Tank - Fork Accessible	\$10,555.60

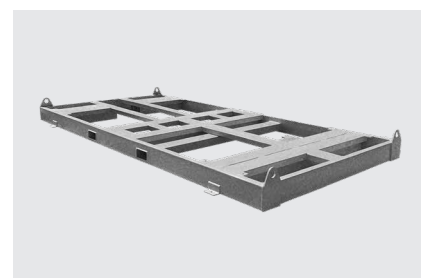

\*\* Except 3000, 5000, 12500 & 17000Ltr Models

† Calibrations and sight tube readings should be taken as an approximate measure of volume

## Liquid Fertiliser Sump-Based Transport Tanks



### FEATURES

- Special 'FNS' series range manufactured for transport of liquid fertilisers and chemicals with heavier SG ratings
- Easy to read calibrations<sup>†</sup>
- Strength through ingenuity of design
- Durable, impact-resistant, UV-stabilised polyethylene for long life
- Stainless steel lid
- Sight tube for easy viewing of content volume<sup>†</sup>
- Two outlets supplied with tank, quantity and sizes optional
- Mounting pins supplied as standard, extra mounting pins available
- Optional Ball Baffle System available
- Optional Skid Frame available
- Poly fittings for easy connection
- Standard colour is white

### Liquid Fertiliser Sump-Based Transport Tanks

Code	Description	Length (mm)	Width (mm)	Height (mm)	List Price (incl. GST)
FNS2000	2,000Ltr Liquid Fert Sump-Based Transport Tank	1830	1400	1130	\$3,297.80
FNS3000	3,000Ltr Liquid Fert Sump-Based Transport Tank	2356	1460	1300	\$4,716.80
FNS5000	5,000Ltr Liquid Fert Sump-Based Transport Tank	2425	1830	1708	\$6,699.00
FNS7000	7,000Ltr Liquid Fert Sump-Based Transport Tank	3430	1850	1670	\$9,105.80
FNS10000	10,000Ltr Liquid Fert Sump-Based Transport Tank	3600	2100	1890	\$12,694.00
FNS12500	12,500Ltr Liquid Fert Sump-Based Transport Tank	4000	2200	2550	\$15,945.60

\*Optional Skid Frames available at extra cost.



Due to the sump position, a Coerco skid frame is recommended for mounting purposes.

<sup>†</sup> Calibrations and sight tube readings should be taken as an approximate measure of volume

## Liquid Fertiliser Sump-Based Transport Tanks



### Liquid Fertiliser Sump-Based Transport Tank Skid Frames

Code	Description	List Price (incl. GST)
SKD-SU-2000HDG	Hot Dip Galvanised Skid Frame To Suit 2,000L Sump-Based Transport Tank - Fork Accessible	\$3,707.00
SKD-FS-3000HDG	Hot Dip Galvanised Skid Frame To Suit 3,000L Sump-Based Transport Tank - Fork Accessible	\$4,669.50
SKD-FS-5000HDG	Hot Dip Galvanised Skid Frame To Suit 5,000L Sump-Based Transport Tank - Fork Accessible	\$5,467.00
SKD-FS-7000HDG	Hot Dip Galvanised Skid Frame To Suit 7,000L Sump-Based Transport Tank - Fork Accessible	\$7,360.10
SKD-SU-10000HDG	Hot Dip Galvanised Skid Frame To Suit 10,000L Sump-Based Transport Tank - Fork Accessible	\$8,217.00
SKD-FS-12500HDG	Hot Dip Galvanised Skid Frame To Suit 12,500L Sump-Based Transport Tank - Fork Accessible	\$9,432.50



## Bulk Liquid Fertiliser Units



### FEATURES

- Heavy duty steel skid frame with two-pack epoxy
- Container lock mounting system to suit a 30-foot skel trailer
- Available in 25,000L or 29,500L capacities
- Fully-baffled tanks using baffle ball system
- Spill containment bunds around fill points
- Access platform and fold-down ladders
- 3-inch poly pump with Honda GX160 Petrol engine
- 3-inch discharge to both sides
- 3-inch delivery hoses in PVC holders (both sides)
- 3-inch fill port (complies with liquid fertiliser supply stations)
- Stainless steel lid with breather and probe port
- Work lights for night use
- Stainless steel toolbox
- 200L freshwater tank for pump rinse and hand wash
- Air assisted flush out system

### Bulk Liquid Fertiliser Units

Code	Description
FNS25000-TS	25,000 Bulk Liquid Fertiliser Unit (2 × 12,500 liquid fertiliser transport tanks)
FNS29500-TS	29,500 Bulk Liquid Fertiliser Unit (1 × 17,000L and 1 × 12,500L liquid fertiliser transport tanks)



Stainless Steel Lid with breather and probe port



Stainless Steel Toolbox

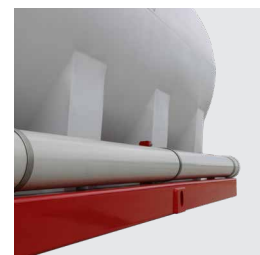

3-inch Delivery Hoses in PVC Holders (both sides)



3-inch Poly Pump with Honda GX160 Petrol Engine



3-inch Discharge (Both sides)



Access Platform and Fold-down Ladders



# Transport Tanks

## Coerco Liquid Transport Tanks, Built as Tough as Aussie Farmers.

Manufactured and designed by Rural Aussies for Rural Aussies, Coerco poly liquid transport tanks have the exact features you need to strengthen your operations.

### KEY FEATURES

- Easy-to-read calibrations
- UV-stabilised for our harsh climate conditions
- Durable and impact-resistant polyethylene
- A vast variety of capacities with baffle systems to choose from
- Suitable for use in any industry and are rust-free



Sight tube for easy viewing of content volume



UV-Stabilised



Standard Colour is White

## Free-Standing Transport Tanks



### FEATURES

- Easy to read calibrations<sup>†</sup>
- Strength through ingenuity of design
- Durable, impact-resistant, UV-stabilised polyethylene for long life
- Sight tube for easy viewing of content volume<sup>†</sup>
- One outlet supplied with tank, quantity and sizes optional
- Secure screw lid
- Integral foam filled baffle to reduce surge and increase stability\*\*
- Mounting pins supplied as standard, extra mounting pins available
- Optional Ball Baffle System available
- All free standing tanks available with forkliftable galvanised skid
- Strainer basket supplied with all tanks
- Standard colour is white

### Free-Standing Transport Tanks

Code	Description	Length (mm)	Width (mm)	Height (mm)	List Price (incl. GST)
ST400FS	400Ltr Free-Standing Liquid Transport Tank	1250	850	650	\$1,020.80
ST600FS	600Ltr Free-Standing Liquid Transport Tank	1350	980	710	\$1,123.10
ST800FS	800Ltr Free-Standing Liquid Transport Tank	1370	1100	860	\$1,381.60
ST1000FS	1,000Ltr Free-Standing Liquid Transport Tank	1370	1210	960	\$1,530.10
ST1500FS	1,500Ltr Free-Standing Liquid Transport Tank	1780	1260	1045	\$2,251.70
ST2000FS	2,000Ltr Free-Standing Liquid Transport Tank	1830	1400	1130	\$2,997.50
ST3000FS	3,000Ltr Free-Standing Liquid Transport Tank - Non Baffled	2365	1460	1300	\$4,120.60
ST5000FS	5,000Ltr Free-Standing Liquid Transport Tank - Non Baffled	2425	1830	1708	\$5,834.40
ST7000FS	7,000Ltr Free-Standing Liquid Transport Tank	3400	1850	1670	\$7,925.50
ST10000FS	10,000Ltr Free-Standing Liquid Transport Tank	3600	2110	2020	\$11,063.80
ST12500FS	12,500Ltr Free-Standing Liquid Transport Tank - Non Baffled	3930	2200	2085	\$13,898.50
ST17000FS	17,000Ltr Free-Standing Liquid Transport Tank - Non Baffled	4630	2330	2350	\$19,566.80

\*\* Except 3000, 5000, 12500 & 17000Ltr Models

† Calibrations and sight tube readings should be taken as an approximate measure of volume

## Free-Standing Transport Tanks

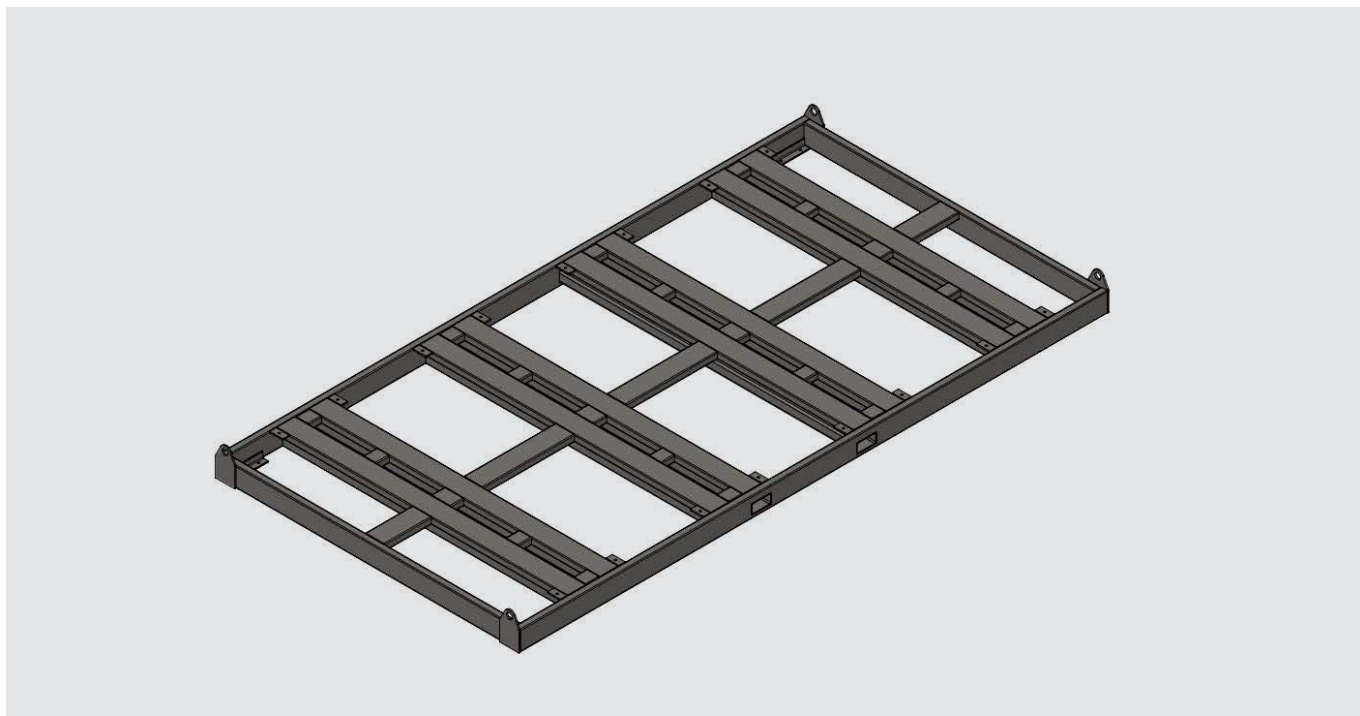

### Free-Standing Transport Tank Skid Frames

Code	Description	List Price (incl. GST)
SKD-FS-400	Duragalv Skid Frame To Suit 400L Free-Standing Transport Tank	\$1,301.30
SKD-FS-600	Duragalv Skid Frame To Suit 600L Free-Standing Transport Tank	\$1,328.80
SKD-FS-800	Duragalv Skid Frame To Suit 800L Free-Standing Transport Tank	\$1,521.30
SKD-FS-1000	Duragalv Skid Frame To Suit 1,000L Free-Standing Transport Tank	\$1,524.60
SKD-FS-1500	Duragalv Skid Frame To Suit 1,500L Free-Standing Transport Tank	\$1,864.50
SKD-FS-2000	Duragalv Skid Frame To Suit 2,000L Free-Standing Transport Tank - Fork Accessible	\$2,340.80
SKD-FS-3000	Duragalv Skid Frame To Suit 3,000L Free-Standing Transport Tank - Fork Accessible	\$3,164.70
SKD-FS-5000	Duragalv Skid Frame To Suit 5,000L Free-Standing Transport Tank - Fork Accessible	\$3,972.10
SKD-FS-7000	Duragalv Skid Frame To Suit 7,000L Free-Standing Transport Tank - Fork Accessible	\$5,777.20
SKD-FS-10000	Duragalv Skid Frame To Suit 10,000L Free-Standing Transport Tank - Fork Accessible	\$6,011.50
SKD-FS-12500	Duragalv Skid Frame To Suit 12,500L Free-Standing Transport Tank - Fork Accessible	\$6,935.50
SKD-FS-17000	Duragalv Skid Frame To Suit 17,000L Free-Standing Transport Tank - Fork Accessible	\$7,426.10



## Sump-Based Transport Tanks

### FEATURES

- Strength through ingenuity of design
- Durable, impact-resistant, UV-stabilised polyethylene for long life
- Easy to read calibrations<sup>†</sup>
- Sight tube for easy view of content volume<sup>†</sup>
- Vented lid and strainer basket supplied with all tanks
- Two outlets supplied with tank, quantity and sizes optional
- Secure screw lid
- Available with robust galvanised steel mounting frame for protection of tank and ease of installation
- Mounting pins supplied as standard for secure fastening, extra mounting pins available
- Optional Ball Baffle System available
- Optional Skid Frame available
- Poly fittings for easy connection
- Standard colour is white



Due to the sump position, a Coerco skid frame is recommended for mounting purposes.



### Sump-Based Transport Tanks

Code	Description	Length (mm)	Width (mm)	Height (mm)	List Price (incl. GST)
ST400	400Ltr Sump-Based Transport Tank	1250	850	650	\$1,068.10
ST600	600Ltr Sump-Based Transport Tank	1350	980	710	\$1,227.60
ST800	800Ltr Sump-Based Transport Tank	1370	1100	860	\$1,525.70
ST1000	1,000Ltr Sump-Based Transport Tank	1355	1210	960	\$1,655.50
ST1500	1,500Ltr Sump-Based Transport Tank	1750	1250	1045	\$2,433.20
ST2000	2000Ltr Sump-Based Transport Tank	1880	1410	1130	\$3,240.60
ST3000	3,000Ltr Sump-Based Transport Tank	2365	1460	1300	\$4,226.20
ST5000	5,000Ltr Sump-Based Transport Tank	2425	1830	1708	\$5,985.10
ST7000	7,000Ltr Sump-Based Transport Tank	3400	1850	1670	\$8,125.70
ST10000	10,000Ltr Sump-Based Transport Tank	3660	2110	2020	\$11,347.60
ST12500	12,500Ltr Sump-Based Transport Tank	3930	2200	2105	\$14,253.80

\* Skid Frames available at extra cost.

# Sump-Based Transport Tanks

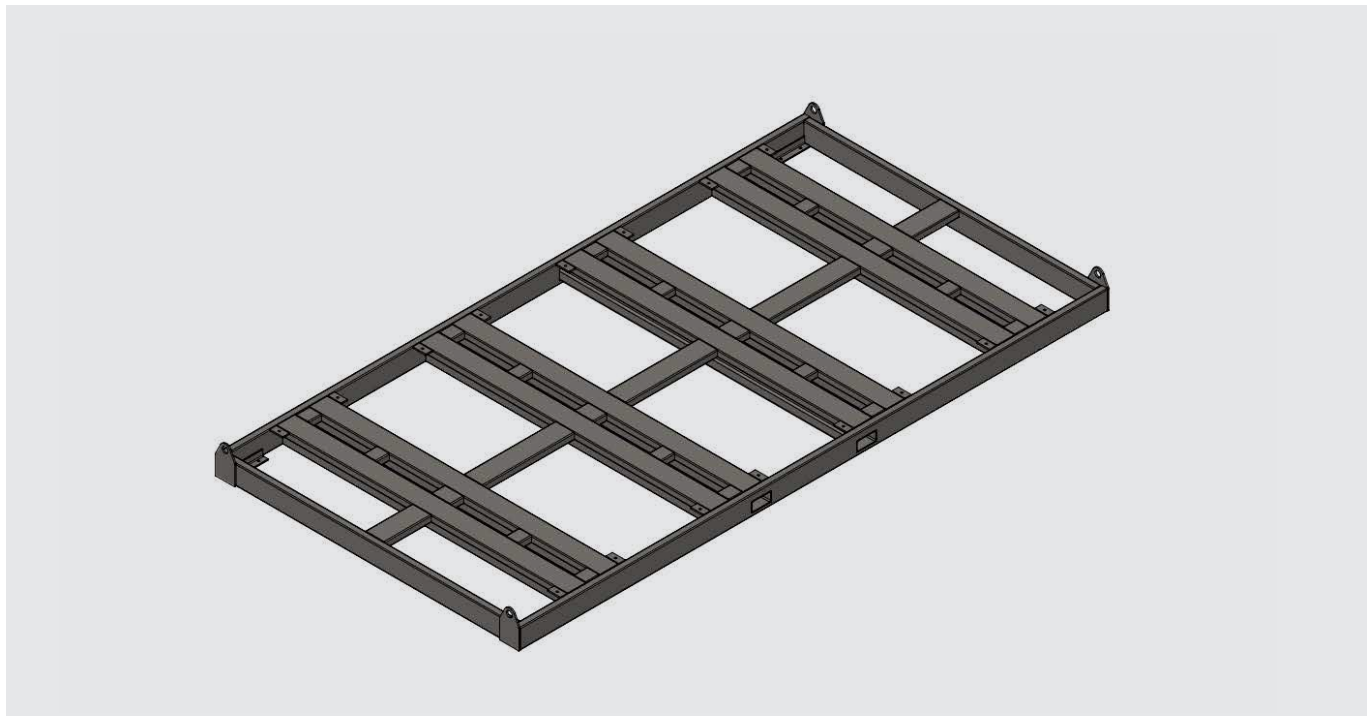

Sump-Based Transport Tank Skid Frames		
Code	Description	List Price (incl. GST)
SKD-SU-400	Duragalv Skid Frame To Suit 400L Sump-Based Transport Tank	\$1,443.20
SKD-SU-600	Duragalv Skid Frame To Suit 600L Sump-Based Transport Tank	\$1,481.70
SKD-SU-800	Duragalv Skid Frame To Suit 800L Sump-Based Transport Tank	\$1,794.10
SKD-SU-1000	Duragalv Skid Frame To Suit 1,000L Sump-Based Transport Tank	\$1,798.50
SKD-SU-1500	Duragalv Skid Frame To Suit 1,500L Sump-Based Transport Tank	\$2,141.70
SKD-SU-2000	Duragalv Skid Frame To Suit 2,000L Sump-Based Transport Tank - Fork Accessible	\$2,487.10
SKD-FS-3000	Duragalv Skid Frame to Suit 3,000L Sump-Based Transport Tank - Fork Accessible	\$3,164.70
SKD-FS-5000	Duragalv Skid Frame To Suit 5,000L Sump-Based Transport Tank - Fork Accessible	\$3,972.10
SKD-FS-7000	Duragalv Skid Frame To Suit 7,000L Sump-Based Transport Tank - Fork Accessible	\$5,777.20
SKD-SU-10000	Duragalv Skid Frame To Suit 10,000L Sump-Based Transport Tank - Fork Accessible	\$6,658.30
SKD-FS-12500	Duragalv Skid Frame To Suit 12,500L Sump-Based Transport Tank - Fork Accessible	\$6,935.50



## Transport Tank Modifications and Accessories

### FEATURES

- Increased vehicle stability
- Reduction in the likelihood of rollover from liquid displacement.
- Increased safety through less driver fatigue.
- Reduction in vehicle maintenance costs (tyres, brakes, etc.).
- Reduction in wear and tear on suspension.
- Improved driving stability on rough terrain and emergency stops.
- Manufactured from food-grade polypropylene.
- CLIP-LOCK Technology - securely fasten each baffle ball, preventing separation and ensuring consistent, long-lasting performance inside your tank
- Compatible with most harsh chemicals and fuels (petrol, diesel, paraffin, etc.).



### Ball Baffle System

Code	Description	List Price (incl. GST)
SBB355	Large Baffle Ball - 355mm	\$16.50



### Transport Tank Lids and Strainer Basket

Code	Description	List Price (incl. GST)
COMP-33-05-PPE	355mm Screw Lid	\$89.10
COMP-33-07-PPE	355mm Strainer Basket	\$70.40
COMP-33-08-PPE	455mm Screw Lid	\$122.10
COMP-33-09-PPE	455mm Strainer Basket	\$84.70
SSTL-455	455mm Stainless Steel Hinged Lid and Seal	\$556.60



# Fire Fighting Equipment

**Take Charge Before Fire Becomes Unstoppable on Your Farm.**

Manufactured and designed by Rural Aussies for Rural Aussies, Coerco fire fighting equipment helps safeguard your investments so you can stay in business.

## KEY FEATURES

- Easy to use, baffled for stability
- Equipped with a genuine Honda GX series engine and Aussie Fire Chief pump with a 5-year pump-end warranty while staying portable
- Range of sizes and models available fit for rural applications



Hot dip galvanised steel hose reel

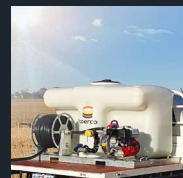

UV-Stabilised



Designed for Easy Operation

## Skid Mount Fire Fighting Units

### FEATURES

- Durable UV-stabilised white coloured polyethylene tank with baffle
- Sight tube for easy view of content volume
- Secure screw lid
- Strong hot dip galvanised steel frame with easy lifting & tie down points - always ready for action
- Hot dip galvanised steel hose reel with 30m of 25mm hose - complete with adjustable nozzle and hose reel lock
- 50mm camlock quick connection fittings
- 6mtr Suction hose with non return foot valve
- Aussie Fire Chief Pump with a 5-Year pump end warranty and powered by a 3-year warranty Honda engine



### Skid Mount Fire Fighting Units

Code	Description	List Price (incl. GST)
FF400C	400Ltr Skid Mounted Fire Fighting Unit	\$6,387.70
FF600C	600Ltr Skid Mounted Fire Fighting Unit	\$6,634.10
FF800C	800Ltr Skid Mounted Fire Fighting Unit	\$6,910.20
FF1000C	1,000Ltr Skid Mounted Fire Fighting Unit	\$7,048.80
FF1500C	1,500Ltr Skid Mounted Fire Fighting Unit	\$7,857.30
FF2000C	2,000Ltr Skid Mounted Fire Fighting Unit	\$9,369.80
FF3000C	3,000Ltr Skid Mounted Fire Fighting Unit	\$10,860.30
FF5000C	5,000Ltr Skid Mounted Fire Fighting Unit	\$13,182.40
FF7000C	7,000Ltr Skid Mounted Fire Fighting Unit	\$16,836.60
FF10000C	10,000Ltr Skid Mounted Fire Fighting Unit	\$20,435.80
FF12500C	12,500Ltr Skid Mounted Fire Fighting Unit	\$24,016.30
FF17000C	17,000Ltr Skid Mounted Fire Fighting Unit	\$29,821.00

## Compact Fire Fighting Units



### Compact Fire Fighting Units

Code	Description	Length (mm)	Width (mm)	Height (mm)	List Price (incl. GST)
FFCH600	600Ltr Compact Fire Fighting Unit	1680	1159	990	\$6,431.70
FFCH800	800Ltr Compact Fire Fighting Unit	1680	1159	1036	\$6,656.10
FFCH1000	1,000Ltr Compact Fire Fighting Unit	1680	1159	1225	\$6,892.60

### Optional Extra

- Diesel powered pump
- Ball Baffle System



### FEATURES

- All sizes with sump drain for complete evacuation of tank contents
- All sizes with forklift access
- Durable UV-stabilised polyethylene tank for long life
- Secure screw lid
- Strong hot dip galvanised steel frame with easy lifting and tie down points
- Hot dip galvanised steel hose reel with 30m of 25mm hose - complete with adjustable nozzle and hose reel lock
- 6mtr suction hose with foot valve
- Aussie Fire Chief Pump with a 5-Year pump end warranty and powered by a 3-year warranty Honda engine
- Compact design to suit tray back utes
- 50mm camlock quick connection fittings

## Wellbody Fire Fighting Units

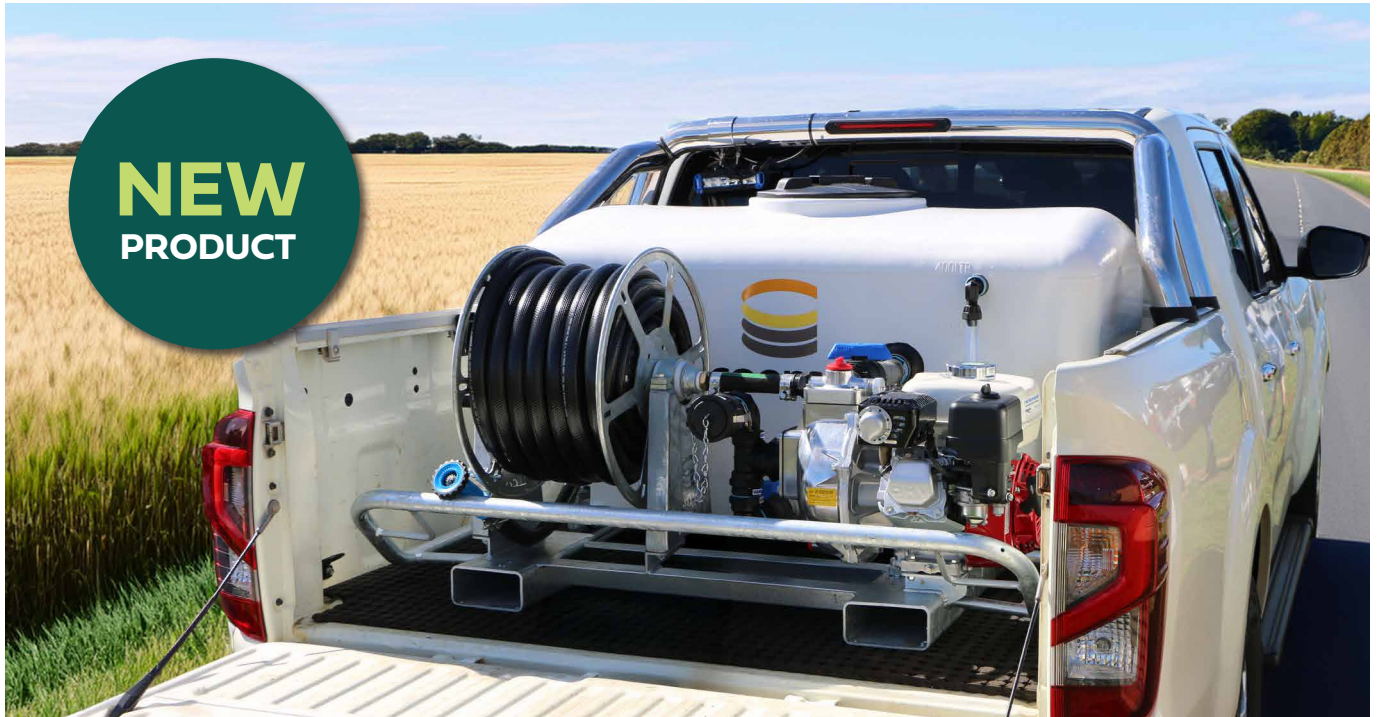

### FEATURES

- Durable UV-stabilised white polyethylene tank for long life
- Hot dipped galvanised steel hose reel with 30m of 25mm hose - complete with adjustable nozzle and hose reel lock
- Forklift accessible
- Secure screw lid
- Aussie Fire Chief Pump with 5-Year pump end warranty powered by a 3-year warranty Honda engine
- Strong hot dip galvanised steel frame with easy lifting and tie down points
- Compact design - to suit well-body utes
- 50mm camlock quick connection fittings
- 6m suction hose with foot valve

### Wellbody Fire Fighting Units

Code	Description	Length (mm)	Width (mm)	Height (mm)	List Price (incl. GST)
FFWB480	480Ltr Wellbody Fire Fighting Unit to Suit Well-Body Utes	1450	1284	787	\$6,814.50

\*Australian Design Registration Nos. 202516762 & 202516763

## Trailed Fire Fighting Units



### FEATURES

- Designed and manufactured for easy operation
- Durable UV-stabilised white coloured polyethylene tank with baffle
- Secure screw lid
- Galvanised chassis frame
- Mudguards and mudflaps
- Heavy duty pivot jockey wheel
- Landcruiser stud pattern rims
- Aussie Fire Chief Pump with a 5-Year pump end warranty, powered by a 3-year warranty Honda engine
- 50mm camlock quick connection fittings
- Hot dip galvanised steel hose reel with 30m of 25mm hose - complete with adjustable nozzle and hose reel lock
- Suction hose with non return foot valve

### Trailed Fire Fighting Units

Code	Description	List Price (incl. GST)
FF600T	600Ltr Single Axle Fire Fighting Trailer Unit	\$13,609.20
FF800T	800Ltr Single Axle Fire Fighting Trailer Unit	\$13,918.30
FF1000T	1000Ltr Single Axle Fire Fighting Trailer Unit	\$14,062.40
FF1000TT	1,000Ltr Tandem Axle Fire Fighting Trailer Unit	\$16,918.00
FF1500TT	1,500Ltr Tandem Axle Fire Fighting Trailer Unit	\$17,637.40
FF2000TT	2,000Ltr Tandem Axle Fire Fighting Trailer Unit	\$18,526.20
FF3000TT	3,000Ltr Tandem Axle Fire Fighting Trailer Unit	\$21,245.40

### Trailed Fire Fighting Unit Accessories

Code	Description	List Price (incl. GST)
MT-SW	Spare Wheel and Carrier	\$730.40
MT-TB	Poly Tool Box	\$961.40

### Brake Systems

Code	Description	List Price (incl. GST)
MT-SAMB	Single Axle Mechanical Override Brakes (Can Be Licensed To 1500kgs)	\$863.50
MT-TAMB	Tandem Axle Mechanical Override Brakes (Can Be Licensed To 2000kgs)	\$863.50
MT-TAEB	Tandem Axle Electric Brakes (Can Be Licensed To 3000kgs)	\$3,363.80

\*3,000L trailer is only available either unbraked or with electric brakes (mechanical brakes are not an option)

### Licensing Requirements

Code	Description	List Price (incl. GST)
MT-LI	License Inspection (Includes Paperwork Ready For Registration)	\$650.10
MT-ILK	Indicator Lamp Kit	\$666.60

## Hose Reels



### FEATURES

- Hot dip galvanised steel frame and base
- Compact design for smooth operation
- Simple winding mechanism
- Strong locking mechanism to prevent accidental unwinding
- High-quality hose and nozzle

### Hose Reels

Code	Description	List Price (incl. GST)
FRX25	Fire Hose Reel - Excluding Hose - To Suit 25mm Hose	\$627.00
FR25	Fire Hose Reel - 25mm Hose @ 30 Mtr	\$861.30



# Diesel Products

## Superior Diesel Storage & Transport Products Across All Industries.

Keep your operations running with safe, reliable, and efficient diesel storage and transport products.

### KEY FEATURES

- Manufactured in guidance to Australian Standards
- One-piece construction
- High-quality diesel grade material
- Storage tanks with dispensing stations
- Range of sizes and models available



UV-Stabilised



Formulated for Diesel Use



Specialised Grade Polyethylene

## Diesel Storage Tanks



### FEATURES

- Complies to Australian Standard AS1940:2017 when Installed Inside an Approved Bund. (Bund is not included with tank)
- High-quality diesel grade material
- UV resistant for Australian conditions
- Easy to install and easy to relocate if required
- 50mm anti-splash and anti-static fill line with non-return valve
- 50mm low level outlet with lockable ball valve tap and camlock
- Level gauge for easy viewing of content volume
- Earth strap and rod

### Diesel Storage Tanks

Code	Description	Diameter (mm)	Height (mm)	List Price (incl. GST)
DDS5000	5,000Ltr Diesel Storage Tank - Excludes Pump	1800	2275	\$5,904.80
DDS10000	10,000Ltr Diesel Storage Tank - Excludes Pump	2540	2500	\$7,178.60



### Diesel Dispensing Pumps and Accessories

Code	Description	List Price (incl. GST)
DDS12V60PK	12V 60LPM Diesel Pump, 6m hose & 25mm auto shut off nozzle	\$4,672.80
DDS240V80PK*	240V 80LPM Diesel Pump, 6m hose & 25mm auto shut off nozzle	\$4,874.10
DDS240V100PK*	240V 100LPM Diesel Pump, 6m hose & 25mm auto shut off nozzle	\$5,035.80

\*Please note that 240 Volt Pumps must be hard wired in by a qualified electrician.

## Trailed Diesel Transport Equipment



### Trailed Diesel Transport Equipment

Code	Description	List Price (incl. GST)
DT600T	600Ltr Single Axle Diesel Trailer Unit	\$18,738.50
DT800T	800Ltr Single Axle Diesel Trailer Unit	\$19,022.30
DT1000T	1,000Ltr Single Axle Diesel Trailer Unit	\$19,202.70
DT1000TT	1,000Ltr Tandem Axle Diesel Trailer Unit	\$22,088.00
DT1500TT	1,500Ltr Tandem Axle Diesel Trailer Unit	\$22,727.10
DT2000TT	2,000Ltr Tandem Axle Diesel Trailer Unit	\$23,652.20
DT3000TT	3,000Ltr Tandem Axle Diesel Trailer Unit	\$26,413.20

### Trailed Diesel Transport Equipment Accessories

Code	Description	List Price (incl. GST)
MT-SW	Spare Wheel and Carrier	\$730.40
MT-TB	Poly Tool Box	\$961.40

### FEATURES

- Purpose built for easy operation and smooth towing
- Landcruiser stud pattern hubs with spring suspension
- Durable tank manufactured with a specialised grade polyethylene formulated for use in diesel tanks
- 40mm diesel transfer pump coupled to Honda GX160 petrol recoil start engine
- 25mm auto rewind hose reel
- 25mm auto shut-off nozzle
- Sight tube for easy view of content volume
- Galvanised chassis frame
- Custom mudflaps
- Heavy duty pivot jockey wheel
- UV-stabilised for long life

## Trailed Diesel Transport Equipment

### Brake Systems

Code	Description	List Price (incl. GST)
MT-SAMB	Single Axle Mechanical Override Brakes (Can Be Licensed To 1500kgs)	\$863.50
MT-TAMB	Tandem Axle Mechanical Override Brakes (Can Be Licensed To 2000kgs)	\$863.50
MT-TAEB	Tandem Axle Electric Brakes (Can Be Licensed To 3000kgs)	\$3,363.80

\*3,000L trailer is only available either unbraked or with electric brakes (mechanical brakes are not an option)

### Licensing Requirements

Code	Description	List Price (incl. GST)
MT-LI	License Inspection (Includes Paperwork Ready For Registration)	\$650.10
MT-ILK	Indicator Lamp Kit	\$666.60

§ Except 3000 & 5000Ltr Models

† Calibrations and sight tube readings should be taken as an approximate measure of volume only.

## Diesel Free-Standing Transport Tanks



### FEATURES

- Integral foam filled baffle to reduce surge and increase stability <sup>§</sup>
- Flat based to allow transport flexibility
- Special grade polyethylene for diesel - coloured to denote "Diesel Only"
- UV-stabilised for long outdoor life
- Mounting pins supplied as standard
- Optional Ball Baffle System available
- All models available with forkliftable galvanised mounting skid
- 2" filler hole with cap, 2" drum pump access fitting and splash resistant vent
- Calibrated for easy checking of content volume with sight tube <sup>†</sup>

### Diesel Free-Standing Transport Tanks

Code	Description	Length (mm)	Width (mm)	Height (mm)	List Price (incl. GST)
DT400FS	400Ltr Free-Standing Diesel Transport Tank	1250	850	650	\$1,171.50
DT600FS	600Ltr Free-Standing Diesel Transport Tank	1350	980	710	\$1,346.40
DT800FS	800Ltr Free-Standing Diesel Transport Tank	1370	1100	860	\$1,700.60
DT1000FS	1,000Ltr Free-Standing Diesel Transport Tank	1355	1210	960	\$1,873.30
DT1500FS	1,500Ltr Free-Standing Diesel Transport Tank	1750	1250	1045	\$2,501.40
DT2000FS	2,000Ltr Free-Standing Diesel Transport Tank	1830	1400	1130	\$3,296.70
DT3000FS	3,000Ltr Free-Standing Diesel Transport Tank - Non Baffled	2365	1460	1300	\$4,822.40
DT5000FS	5,000Ltr Free-Standing Diesel Transport Tank - Non Baffled	2425	1830	1708	\$6,846.40
DT7000FS	7,000Ltr Free-Standing Diesel Transport Tank	3430	1850	1670	\$9,309.30
DT10000FS	10,000Ltr Free-Standing Diesel Transport Tank	3600	2100	1890	\$12,977.80
DT12500FS	12,500Ltr Free-Standing Diesel Transport Tank - Non Baffled	4000	2200	2085	\$16,302.00
DT17000FS	17,000Ltr Free-Standing Diesel Transport Tank - Non Baffled	4450	2300	2350	\$22,370.70

## Diesel Free-Standing Transport Tanks

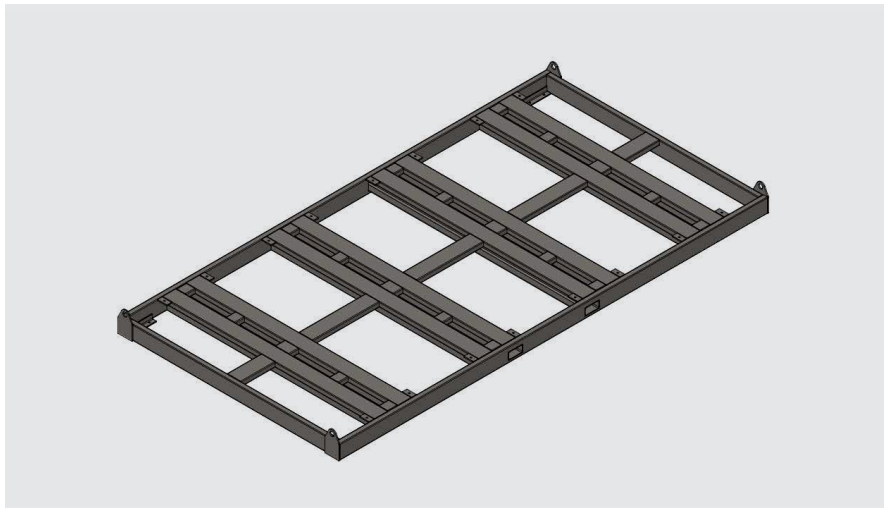

### Diesel Free-Standing Transport Tank Skid Frames

Code	Description	List Price (incl. GST)
SKD-FS-400	Duragalv Skid Frame To Suit 400L Free-Standing Transport Tank	\$1,301.30
SKD-FS-600	Duragalv Skid Frame To Suit 600L Free-Standing Transport Tank	\$1,328.80
SKD-FS-800	Duragalv Skid Frame To Suit 800L Free-Standing Transport Tank	\$1,521.30
SKD-FS-1000	Duragalv Skid Frame To Suit 1,000L Free-Standing Transport Tank	\$1,524.60
SKD-FS-1500	Duragalv Skid Frame To Suit 1,500L Free-Standing Transport Tank	\$1,864.50
SKD-FS-2000	Duragalv Skid Frame To Suit 2,000L Free-Standing Transport Tank - Fork Accessible	\$2,340.80
SKD-FS-3000	Duragalv Skid Frame to Suit 3,000L Free-Standing and Sump-Based Transport Tank – Fork Accessible	\$3,164.70
SKD-FS-5000	Duragalv Skid Frame To Suit 5,000L Free-Standing and Sump-Based Transport Tank – Fork Accessible	\$3,972.10
SKD-FS-7000	Duragalv Skid Frame To Suit 7,000L Free-Standing and Sump-Based Transport Tank – Fork Accessible	\$5,777.20
SKD-FS-10000	Duragalv Skid Frame To Suit 10,000L Free-Standing Transport Tank - Fork Accessible	\$6,011.50
SKD-FS-12500	Duragalv Skid Frame To Suit 12,500L Free-Standing and Sump-Based Transport Tank – Fork Accessible	\$6,935.50
SKD-FS-17000	Duragalv Skid Frame To Suit 17,000L Free-Standing Transport Tank - Fork Accessible	\$7,426.10

## Diesel Transport Units



### FEATURES

- Durable UV-stabilised polyethylene tank with specialised grade polyethylene suitable for diesel
- Baffle Ball System for improved load stability
- Galvanised steel frame with fork access and platform for pumping equipment and plumbing
- 40mm cast iron diesel transfer pump coupled to Honda GX160 petrol recoil start engine
- 32mm filter with pressure gauge
- 25mm auto rewind hose reel (with 15m of hose)
- 25mm auto shut-off nozzle and nozzle holder
- 50mm fill line (independent of pump) including non-return valve
- Sight tube for easy view of content volume
- Ability to fill tank through pump

### Diesel Transport Units

Code	Description	Length (mm)	Width (mm)	Height (mm)	List Price (incl. GST)
DTU2000	2,000L Diesel Transport Unit	2795	1400	1230	\$16,142.50
DTU3000	3,000L Diesel Transport Unit	3220	1538	1450	\$18,505.30
DTU5000	5,000L Diesel Transport Unit	3180	1836	1858	\$22,352.00
DTU7000	7,000L Diesel Transport Unit	4240	1850	1820	\$26,503.40
DTU10000	10,000L Diesel Transport Unit	4420	2110	2150	\$32,671.10
DTU12500	12,500L Diesel Transport Unit	4555	2200	2235	\$37,524.30
DTU17000	17,000L Diesel Transport Unit	5485	2345	2500	\$45,699.50

### Diesel Transport Unit Accessories

Code	Description	List Price (incl. GST)
MT-DHA40-U	40mm Auto Rewind Hose Reel - Upgrade from 25mm	\$2,921.60
MT-ASN40-U	40mm Auto Shut-Off Nozzle - Upgrade From 25mm	\$638.00
MT-FM40	40mm BSP Port 4 Digit Flow Meter	\$3,241.70
MT-FM4	25mm BSP Port 4 Digit Flow Meter	\$331.10

## Diesel Transfer Accessories

### FEATURES

- Diesel Pump Kits for refuelling operations from drums, tanks or mobile refuelling carts
- Robust proven pump kits for diesel refuelling operations
- Designed to give effortless refuelling for agricultural operations

### Diesel Transfer Accessories

Code	Description	List Price (incl. GST)
MT-12A45K	12 Volt Pump Kit With Auto Shut-Off Nozzle - 45Lpm	\$852.50
MT-12A60K	12 Volt Pump Kit With Auto Shut-Off Nozzle - 60Lpm	\$1,041.70
MT-12AHF	12 Volt Hi-Flo Pump Kit With Auto Shut-Off Nozzle - 85Lpm	\$1,485.00
MT-FM4	25mm BSP Port 4 Digit Flow Meter, Manual	\$331.10
MT-FMD	25mm BSP Electronic Inline Digital Flow Meter For Diesel	\$530.20
MT-FM40	40mm BSP Port 4 Digit Flow Meter, Manual	\$3,241.70
MT-DHA25	25mm Auto Rewind Diesel Hose Reel	\$1,883.20
MT-DHA40	40mm Auto Rewind Diesel Hose Reel	\$5,035.80
MT-ASN25	25mm Auto Shut-Off Nozzle	\$410.30
MT-ASN40	40mm Auto Shut-Off Nozzle	\$928.40
MT-DF	1 ¼ Inch Diesel Filter with Gauge	\$407.00
MT-DF10	1 Inch 10 Micron Fuel Filter	\$261.80
MT-MSN40	1 ½ Manual Shut-off Nozzle	\$441.10



#### MT-12A45K

- 45L/min open flow
- 4 metres of 20mm anti-static delivery hose with anti-kink spring + auto shut-off nozzle
- 4 metres of power cable
- 2 metres of 20mm suction hose
- On/off switch on pump



#### MT-12A60K

- 60L/min open flow
- 4 metres of 25mm anti-static delivery hose with anti-kink spring + auto shut-off nozzle
- 4 metres of power cable
- 2 metres of 25mm suction hose
- Easy clean suction strainer



#### MT-12AHF

- 85 L/min open flow
- 12 volt DC/35 amp pump
- 4 metre battery cable with alligator clips
- Easy to use volumetric self priming
- 1" BSP female ports
- 4 metres of 25mm diesel delivery hose
- Auto shutoff nozzle with swivel



#### MT-FMD

- 1" BSP electronic inline turbine meter with compact display ideal for fitting at fuel nozzles
- Flow range 10-120 LPM maximum, working pressure 300 PSI, accuracy ± 1%.



#### MT-DHA25

- Hose reel with 15m x 25mm hose. 1" BSP inlet/outlet. air/water/diesel
- 300 PSI working pressure



#### MT-FM4

- 1" BSP port 4 digit flow meter with flow range from 20 - 120 LPM
- 4 digit resettable totaliser. 8 digit non resettable cumulative total
- For use with diesel fuel in pump or gravity applications.



#### MT-ASN25

- 1" BSP port
- Auto shut-off



# Septic Systems

**Beat the Old – Coerco’s Premium Septic Systems are Conveniently the Best.**

Designed by experienced rural Aussies, Coerco’s poly septic and leach drain systems offer hassle-free delivery, installation, and performance—reliable, easy to use, and great value without compromising quality.

## KEY FEATURES

- Manufactured to meet Department of Health approvals: Western Australia, Northern Territory, and South Australia
- Certified to AS1546.1 for a range of septic and wastewater products
- Variety of sizes to suit your requirements



UV-Stabilised

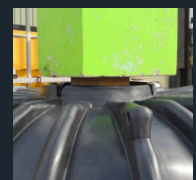

Made of Polyethylene

## Septic Tanks



### FEATURES

- Lightweight, easy to transport and install
- Manufactured from durable polyethylene
- Anti floatation ring and ribbing incorporated into design
- Certified to Australian Standard AS/NZS1546.1 and approved by Department of Health - WA
- Supplied as complete kit including lid, inlet and outlet 'T' pieces
- Leach drain systems also available

### Septic Tanks

Code	Description	Diameter (mm)	Height (mm)	List Price (incl. GST)
SEP-1450	1,450Ltr Septic Tank	1250	1500	\$1,234.20
SEP-2200	2,200Ltr Septic Tank	1540	1500	\$1,289.20
SEP-3200	3,200Ltr Septic Tank	2150	1745	\$2,445.30
SEP-4000	4,000Ltr Septic Tank	2200	1730	\$2,784.10

### Septic Tank Accessories

Code	Description	List Price (incl. GST)
EFD-100	100mm Effluent Diverter	\$221.10

\* To comply with Australian Standards requirement of minimum 3000L septic tank volume, our SEP-2200 and SEP-1450 can be combined. For a single-tank solution, our SEP-3200 is the ideal option; Septic tank colour may vary depending on the recycled material used.

# HydraDrain Modular Leach Drains

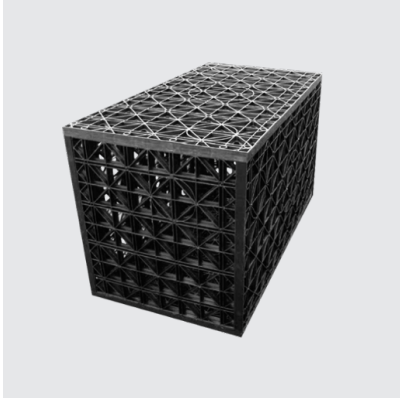

## HydraDrain Modular Leach Drains

Code	Description	List Price (incl. GST)
LD-04	Leach Drain - 4 Mtr (Includes Cells & Geocloth to suit)	\$432.30
LD-05	Leach Drain - 5 Mtr (Includes Cells & Geocloth to suit)	\$497.20
LD-06	Leach Drain - 6 Mtr (Includes Cells & Geocloth to suit)	\$557.70
LD-07	Leach Drain - 7 Mtr (Includes Cells & Geocloth to suit)	\$682.00
LD-08	Leach Drain - 8 Mtr (Includes Cells & Geocloth to suit)	\$744.70
LD-09	Leach Drain - 9 Mtr (Includes Cells & Geocloth to suit)	\$864.60
LD-10	Leach Drain - 10 Mtr (Includes Cells & Geocloth to suit)	\$927.30
LD-11	Leach Drain - 11 Mtr (Includes Cells & Geocloth to suit)	\$1,051.60
LD-12	Leach Drain - 12 Mtr (Includes Cells & Geocloth to suit)	\$1,113.20
LD-13	Leach Drain - 13 Mtr (Includes Cells & Geocloth to suit)	\$1,172.60
LD-14	Leach Drain - 14 Mtr (Includes Cells & Geocloth to suit)	\$1,295.80
LD-15	Leach Drain - 15 Mtr (Includes Cells & Geocloth to suit)	\$1,360.70
LD-16	Leach Drain - 16 Mtr (Includes Cells & Geocloth to suit)	\$1,485.00
LD-17	Leach Drain - 17 Mtr (Includes Cells & Geocloth to suit)	\$1,543.30
LD-18	Leach Drain - 18 Mtr (Includes Cells & Geocloth to suit)	\$1,667.60
LD-19	Leach Drain - 19 Mtr (Includes Cells & Geocloth to suit)	\$1,728.10
LD-20	Leach Drain - 20 Mtr (Includes Cells & Geocloth to suit)	\$1,853.50

## FEATURES

- Made from 100% recycled material
- Light weight
- Modular
- 95% void area
- Strong
- Service temperature from -20°C – 120°C
- Polypropylene
- Flat pack form

## BENEFITS

- Environmentally friendly
- Simple to install
- Easy to deliver
- Cost effective
- Chemically inert
- Not affected by mould or algae
- UV-stabilised
- Water saving
- 100% recyclable

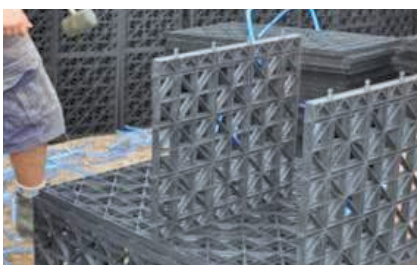

# General Conditions

---

## Product Benefits

Coerco's products are manufactured from the highest food grade material conforming to Australian standards. These products are strong, lightweight, UV resistant and exceptionally durable.

## Product Specifications

All specifications are subject to change in line with ongoing improvements.

## Pricing Includes GST

All prices specified include GST and are subject to change without notice.

## Product Design Protection

Many of Coerco products are subject of an Australian patent and pending design registration.

## Sizes

All sizes, measurements and capacities throughout this brochure are only approximate due to the variable shrinkage nature of polyethylene during manufacture.

## Placing Your Order

We have a diverse network of distributors throughout Western Australia. Contact your local Coerco agent or call us on 1800 646 277.

## Product Returns

All products returned for credit must be in "As New" condition and are subject to a 20% restocking fee and a return freight cost.

## Warranty

Coerco's products are guaranteed against faulty workmanship and carry a warranty. To see the full warranty details go to <https://agriculture.coerco.com.au/warranty>

## Minimum Orders

Any order under \$55 including GST is subject to a postage and handling fee of \$25.00 including GST.

## Disclaimer

All recommendations within this product catalogue are intended as suggestions only. Coerco does not take any responsibility for the suitability of any product for the use it is given. Product images are a close guide only and may not represent actual product.

## Trademarks & Copyright

© Coerco 2026. This publication is copyrighted to Coerco.

# Delivery Information

---

When purchasing a tank from Coerco, it is very important to you provide as much information about delivery as possible. Ideally, the Google Maps latitude and longitude coordinates are the best and most accurate way to tell us where you want your tank delivered.

## Other Options

Another option is a clearly defined instruction on a recent map or, as last preference, an address with well-outlined written drop-off instructions. A site contact phone number should also be provided.

## Clearance

Please note that Coerco's truck and trailer combinations require a minimum clearance of 20 metres long, 3.5 metres wide and 5 metres high.

Please be aware that it is the owner's responsibility to provide clear access to the site. Clear access on roads, lane ways, through gateways, crossings and trees is essential to ensure the safe delivery of your tank/s or other product/s without damage.

Large tanks can be delivered directly to a property where there is a properly made road and large turning area available. If a driver cannot reach the location, the tank/s will be left at the closest practical position.

## General guide for placement of tanks on tank pads

Placement of tanks above 9,500Ltr on a pad requires customer assistance. The following is a general guide to follow (please note that this is a GUIDE ONLY; safe work practices and lifting techniques are to be followed at all times and are the responsibility of the client to observe):

- Tanks between 9,500Ltr and 13,500Ltr need three persons (not including our driver) to handle and manoeuvre into place.
- Tanks between 22,500Ltr and 32,000Ltr need four persons (not including our driver) to handle and manoeuvre into place.

Tanks above 50,000Ltr are too heavy to safely manoeuvre by hand and require either a machine (telehandler, forklift or bobcat) to assist. Alternatively, our logistics team will arrange for the delivery and placement to be conducted with a Hiab equipped truck. This will be discussed and determined during the delivery scheduling call with the customer. Please be reminded that it is the customer's responsibility to ensure there is adequate assistance and/or resources available to safely unload your tank.

If you have any questions regarding your delivery, please give us a call on 1800 646 277 and speak with one of our friendly team members to discuss!

# Delivery Information

## FREIGHT

### Zone 1

Any product or product combination 9,000L or greater includes free delivery to site. All other deliveries are Free Into Store to your local distributor. \*Within 800kms of Perth, WA.

### Zone 2

For locations outside of Zone 1, please contact us for a highly competitive quote for delivery as per your requirements. We have the largest distribution network throughout Western Australia and our own fleet of delivery vehicles with the capability to deliver throughout Australia and further afield. We deliver when it suits our customers, not according to anyone else's schedule.



### Tank Order Form\*

Date		Tank No.	___ of ___
Contact Name			
Product Code		Colour	
Delivery Address			
Phone			

\*Please fill out one sheet for each water tank you order

## ROUND TANKS

### Outlet

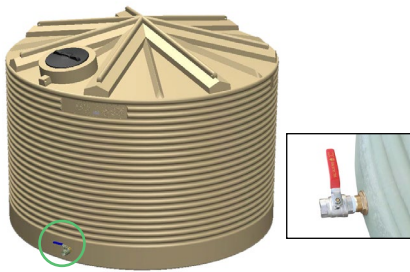

Positioned slightly above the bottom of the tank side wall and is where you connect your tap for draining

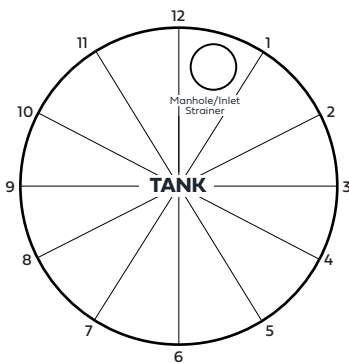

Please mark an **X** on the illustration below where you would like your outlet to be. **This can be positioned at any location from 1 to 12 o'clock.**

#### Choose outlet size:

- 40mm (standard)
- 50mm
- 80mm (additional cost)
- 100mm (additional cost)

### 90mm PVC Overflow

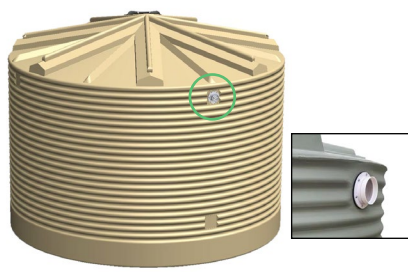

Positioned at the top of the tank side wall and is designed to prevent the tank overflowing in an uncontrollable manner.

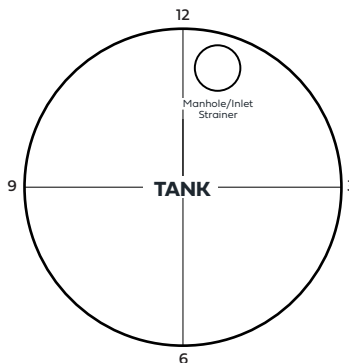

Please mark an **O** on the illustration below where you would like the overflow to be. **This can be positioned at 3, 6, 9, or 12 o'clock.**

### Threaded Inlet (Optional)

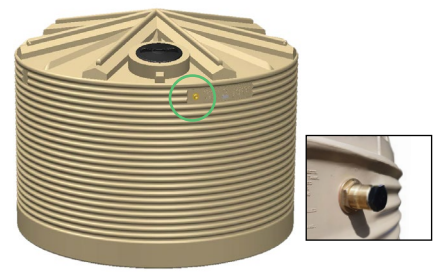

Required only if you are pumping into the tank or filling from a bore NOT when filling from a roof to collect rainwater.

We recommend this is fitted at 12 o'clock so it can be easily accessed through the manhole opening.

#### Choose inlet size:

- 25mm
- 32mm
- 40mm (standard)
- 50mm

### Additional Notes & General Comments

---



---



---



---

Tank Order Form*			
Date		Tank No.	___ of ___
Contact Name			
Product Code		Colour	
Delivery Address			
Phone			

\*Please fill out one sheet for each water tank you order

### LID & LEAF STRAINER POSITION

**RTS800, RTS1500**

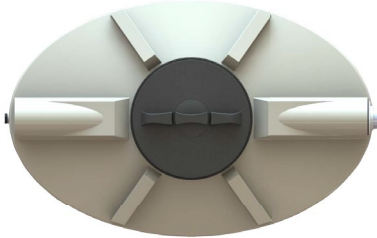

**RTS3000**



### SLIMLINE TANKS

**25mm Drain Outlet**

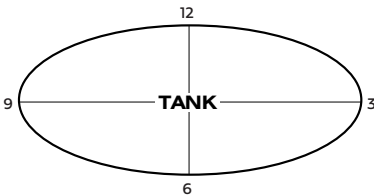

Please mark an **X** where you would like the drain outlet fitted.

This can be positioned at 3, 6, 9 or 12 o'clock

**Hi-Tap**

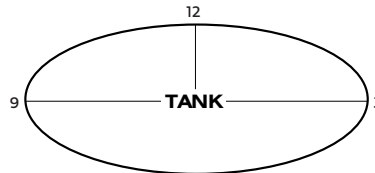

Please mark an **X** where you would like the hi-tap fitted.

For the **RTS1500 & RTS3000** This can be positioned at 3, 9, or 12 o'clock.

For the **RTS800** this can only be positioned at 12 o'clock.

**90mm PVC Mesh Overflow**

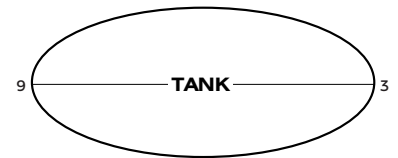
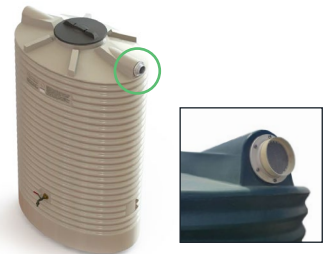

Please mark an **X** where you would like the overflow fitted.

This can be positioned at 3 or 9 o'clock.

### Additional Notes & General Comments

---



---



---



---







# Get in touch today for a no obligation chat and free quotation

**P** 1800 646 277

**E** [info@coerco.com.au](mailto:info@coerco.com.au)

**W** [coerco.com.au](http://coerco.com.au)



## **Dalwallinu Office**

9 Huggett Drive  
Dalwallinu  
Western Australia, 6609

## **Malaga Office**

133 Beringarra Ave.  
Malaga  
Western Australia, 6090

Coerco Pty Ltd  
ABN 54 145 356 565

PO BOX 319 Dalwallinu  
Western Australia 6609